



RENAULT

by:

Iva Graovac
Nevena Žižović
Anja Dričić

-
- Groupe Renault is a French multinational automobile established in 1898.
 - The company produces a range of cars and vans, trucks, tractors, tanks, buses/coaches and autorail vehicles.
 - In 2017 Renault became world's biggest seller.
 - Company headquarter is in Boulogne-Billancourt.
 - Renault was founded by Luis, Marcel and Fernand Renault.

DESIGN

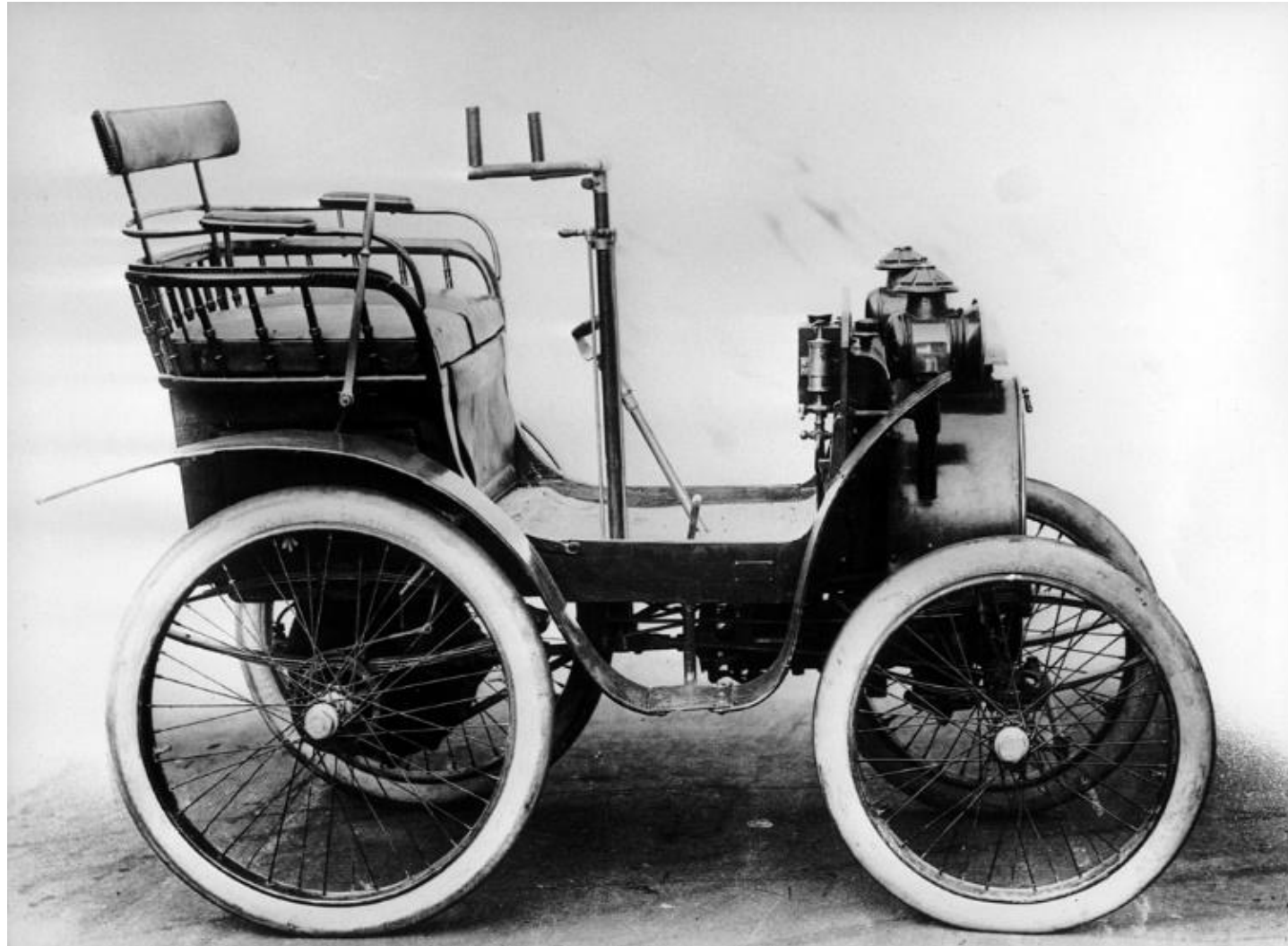

Renault 2



RENAULT 3



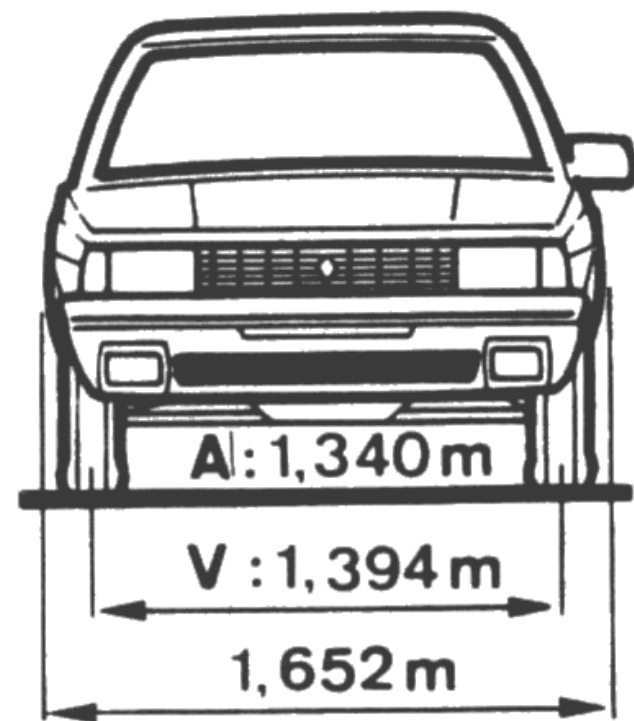
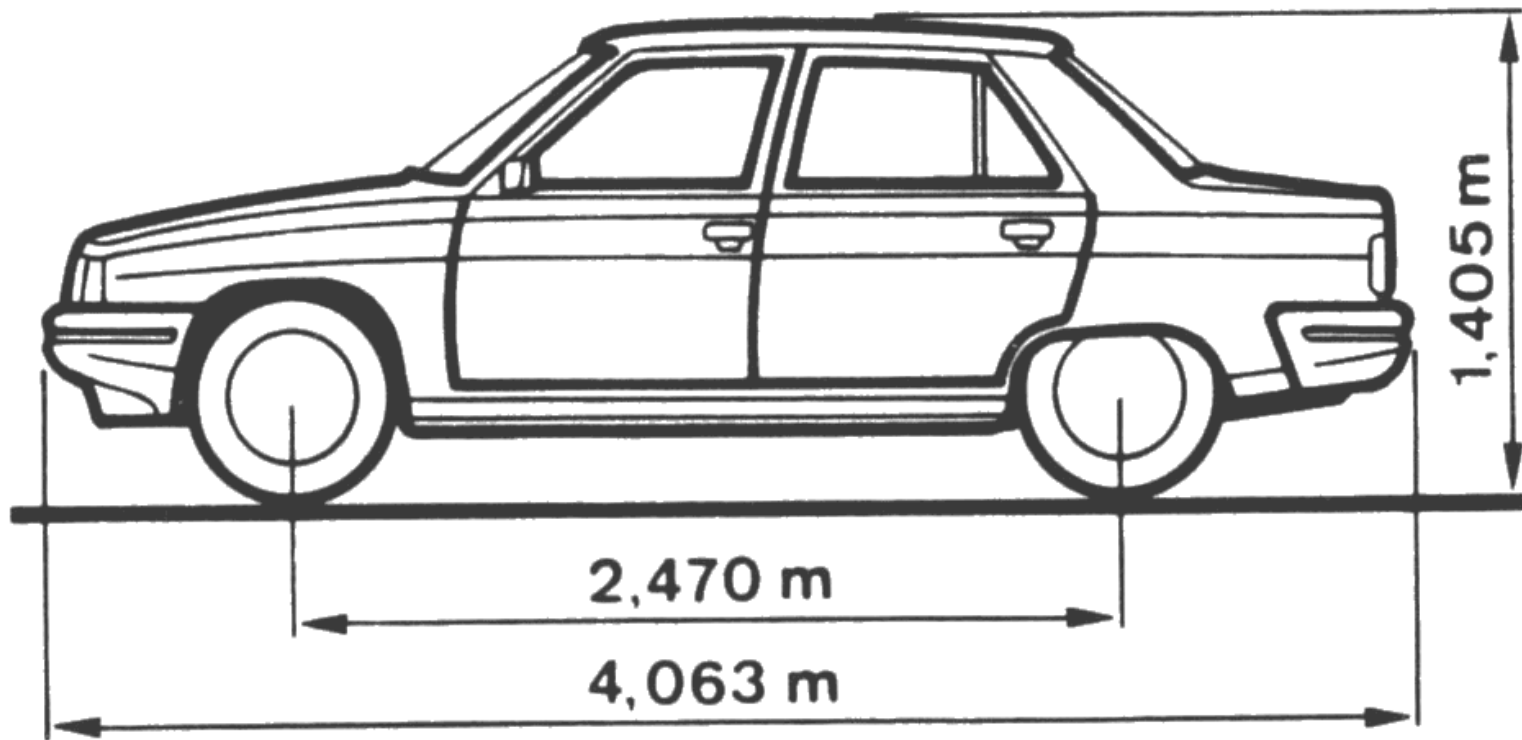

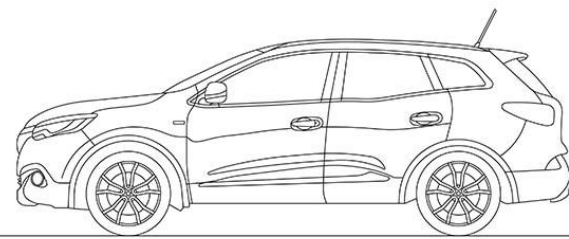
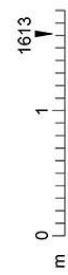
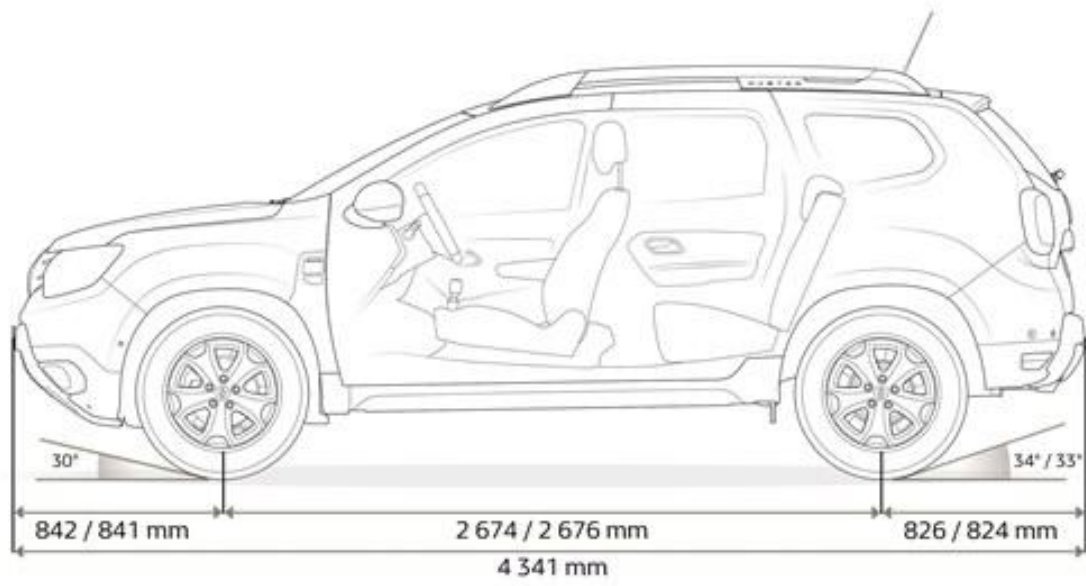

dwgmodels.com

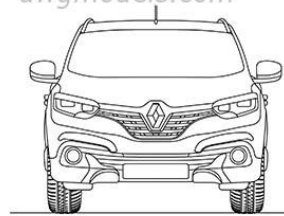

dwgmodels.com

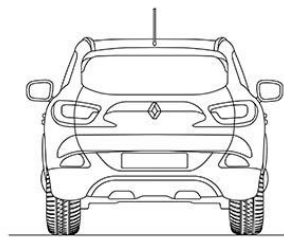
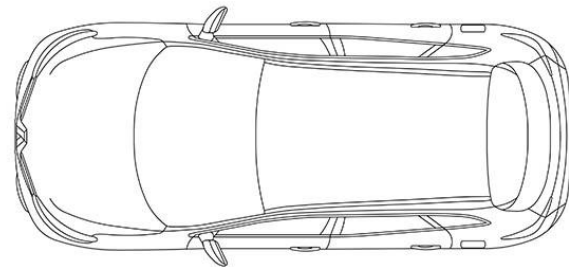

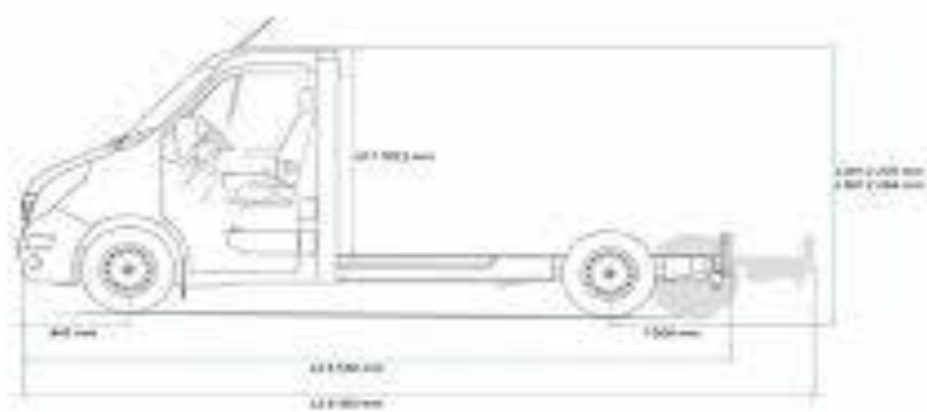
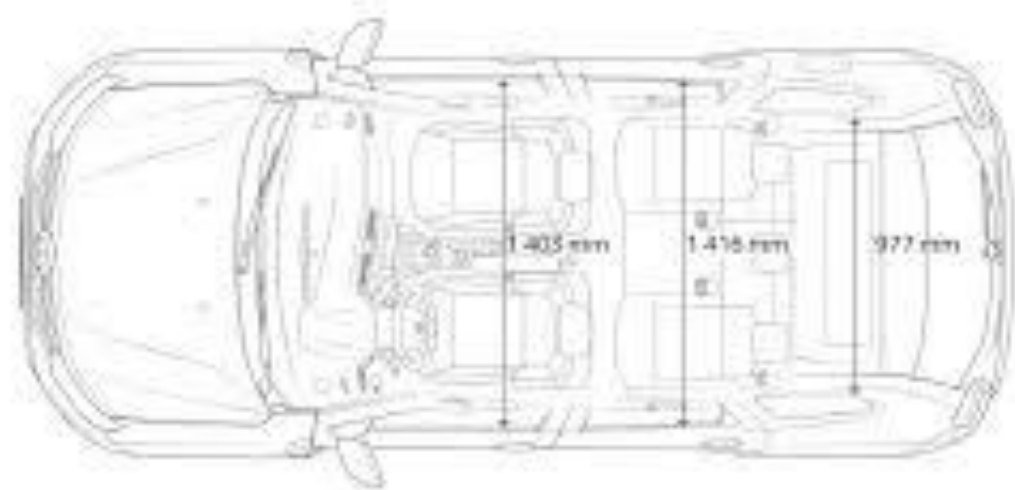

RENAULT 4

- The Renault 4, also known as the 4L.
- It was the best sold car in the Europe from Renault's cars.
- The first million cars were produced by 1 February 1966.





Renault 4

»mali div«

Velika funkcionalnost, jeftino održavanje i mala potrošnja goriva svrstava RENAULT 4 u red najekonomičnijih automobila na cestama Evrope.

Renault 4
Zapremina: 845 cm³
Snaga motora: 25 KW (34 KS)
Potrošnja: 90 km/h: 6,3 l

Renault GTL
Zapremina: 1108 cm³
Snaga motora: 25 KW (34 KS)
Potrošnja: 90 km/h: 5,4 l

NOVO!
Zagarantirana cijena danom uplate.
Kratki rok isporuke
U »Auto-Hrvatskoj« u Zagrebu i Karlovcu zamjena staro za novo.
RENAULT 4.

INDUSTRIJA MOTORNIH VOZIL NOVO MESTO 

RENAULT 4

Advertising about new model
(SFRJ)



SOME OF NEWSPAPERS

Renault



LA PLUS MAGNIFIQUE RÉFÉRENCE
AU RALLYE DE MONTE CARLO

1^{er}
RENAULT

AVEC UNE NERVASPORT PILOTÉE PAR LAMAYE
& QUATRESOUS DEVANT 170 CONCURRENTS
APPARTENANT A 21 NATIONALITÉS

La performance accomplie dans la plus dure
épreuve automobile du monde par une
Nervasport RENAULT est la plus magnifique
témoignage dont puisse se glorifier une industrie.
Toutes les RENAULT possèdent les mêmes
qualités d'accélération, de vitesse, de maniabilité,
de résistance et de finition. Les Usines RENAULT,
les plus complètes du monde, par la vitesse
de leur conception, construisent des voitures
de la plus haute qualité au meilleur prix.

LA NOUVELLE VIVANTINA
"GRAND SPORT"

RENAULT - L'AUTOMOBILE DE FRANCE

NEWS HEADLINES

Renault makes artic disc debut

The world's first artic disc was unveiled at the end of the week in Western Australia as the latest Renault innovation. The new Renault artic disc is a new type of the major artic disc, weighing 1000 kg with a disc diameter of 1000 mm.

This latest disc is a new type of artic disc, weighing 1000 kg with a disc diameter of 1000 mm. It is a new type of the major artic disc, weighing 1000 kg with a disc diameter of 1000 mm.

British bosses to review transport

■ Bill of Britain's transport bosses to review the country's transport system. The review will be led by the Transport Secretary, Lord Carron, and will include a study of the country's transport system.

■ Lord Carron's review will be led by the Transport Secretary, Lord Carron, and will include a study of the country's transport system.

Channel giants chase Scottish CalMac ferries



The British-owned CalMac ferries are being challenged by the Channel Islands' ferries. The Channel Islands' ferries are being challenged by the British-owned CalMac ferries.

RNA is angered by DTIP spend freeze

■ The Royal National Association (RNA) is angered by the DTIP spend freeze. The RNA is angered by the DTIP spend freeze.

Renault 4GTL - mali divci još jači i udobniji!

NOVO 1008 cm³

vožite se ekonomično, udobno i pouzdano - Renault 4GTL!

INDUSTRIJA MOTORNIH VOZILA NOVO MESTO

Renault 4GTL - mali divci još jači i udobniji!

NOVO 1008 cm³

vožite se ekonomično, udobno i pouzdano - Renault 4GTL!

INDUSTRIJA MOTORNIH VOZILA NOVO MESTO

Renault 4 »mali divci«

Velika funkcionalnost, jeftino održavanje i mala potrošnja goriva avajta Renault 4 u red najkvalitetnijih automobila na cestama Evrope.

Renault 4
Zapremina: 845 cm³
Snaga motora: 25 KW (34 KS)
Potrošnja: 30 km/h, 6,2 l

Renault GTL
Zapremina: 1108 cm³
Snaga motora: 25 KW (34 KS)
Potrošnja: 30 km/h, 5,4 l

NOVO!
Zagarantirana cijena danom uplate.
Kratki rok isporuke
U »Auto-Hrvatskoj« u Zagrebu i Karlovcu zamjena stara za nova.
RENAULT 4.

INDUSTRIJA MOTORNIH VOZILA NOVO MESTO

- Za sve informacije obratite se s povjerenjem na:
- BMV, Zagreb, 041/274-290
 - BMV, Osijek, 054/22-140
 - BMV, Zadar, 057/33-047
 - BMV, Rijeka, 051/23-520
 - BMV, Split, 058/45-584
 - »Auto-Hrvatska«, Zagreb, 041/529-234
 - »Auto-Hrvatska«, Karlovec, 047/27-244
 - »Auto-Hrvatska«, Slavonski Brod, 058/231-275
 - »Auto-Hrvatska«, Varaždin, 042/44-485
 - »Auto-Hrvatska«, Pula, 052/24-984
 - »Auto-Hrvatska«, Šibenik, 058/24-423
 - »Auto-Hrvatska«, Križ, 059/60-081
 - »Auto-Hrvatska«, Slavonski Brod, 058/232-244
 - RO »Auto-kuća«, Čakovice, 042/811-450

IT'S WASHING TIME!

Old empire of dreams

THE MOST UNIQUE TOURING PLAN FOR EUROPE RENAULT

products are guaranteed for parts and service for one year

THE NEW YORK TIMES Sports

The Old Coaches Endure

Tal Smith Enjoys New Pitch

Swan's Showing Cheers Mets

Northeastern Given Home-Ice Edge in N.C.A.A. Tourney

AUTOMOBILE EXCHANGE

\$500 OFF ON ALL NEW 1982 HONDA

REEDMAN

REMARKABLE RENAULT VALUES!

\$7395 up to \$2000

\$4995

ENORMOUS

The New York Times

Renault from inside







RENAULT EVOLUTION

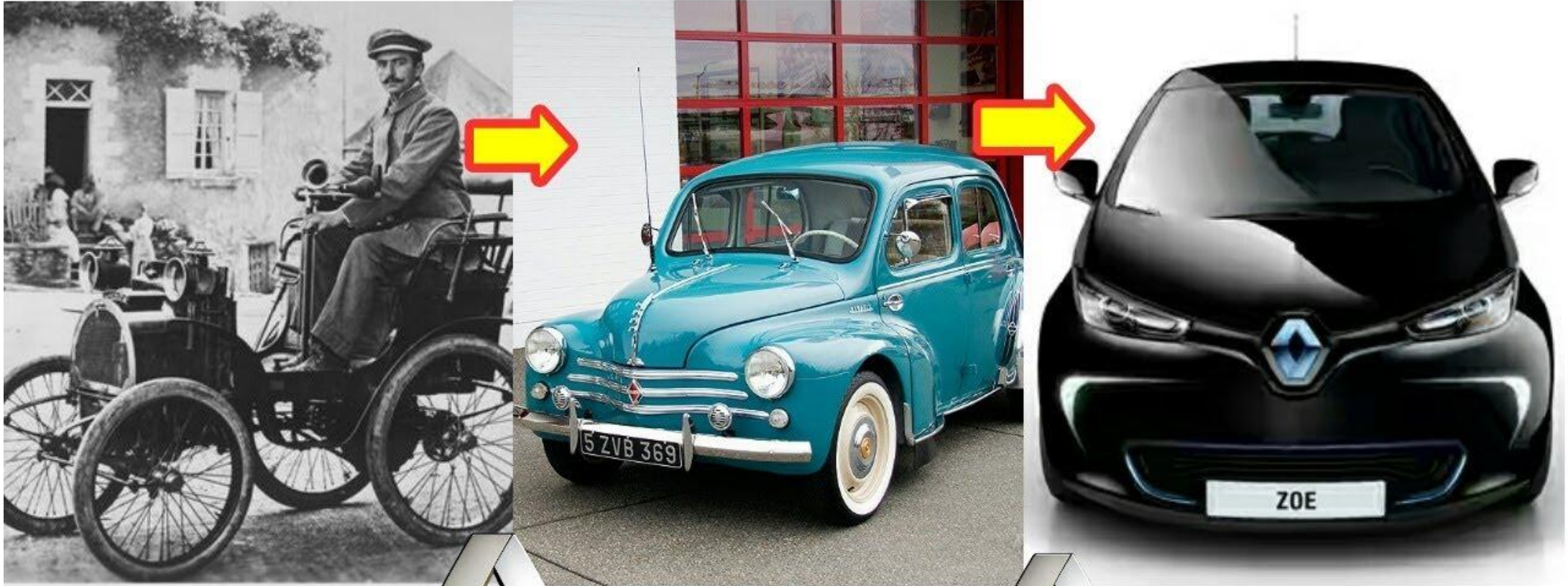

1898



RENAULT

1947



RENAULT

2018

- Design is a primordial factor in market success for a vehicle.
- Though the technical aspects of design work are much more complex to describe, design personnel obviously require imagination, creativity and an acute sense of aesthetics.
- The Design Department is directly responsible for everything motorists see, feel and hear in their vehicles: for everything the customer perceives, for everything that generates an aesthetic response and practical satisfaction.

- Design involvement starts with the initial drafting of specifications and continues right through to production release.
- The department has a network of five international design centres, staffed by multicultural profiles (27 nationalities).
- Skills span everything from traditional craftsmanship (physical modelling, upholstery, paintwork) to advanced technologies (digital modelling and visualization, interactive design), and are driven by a real enthusiasm for the automobile

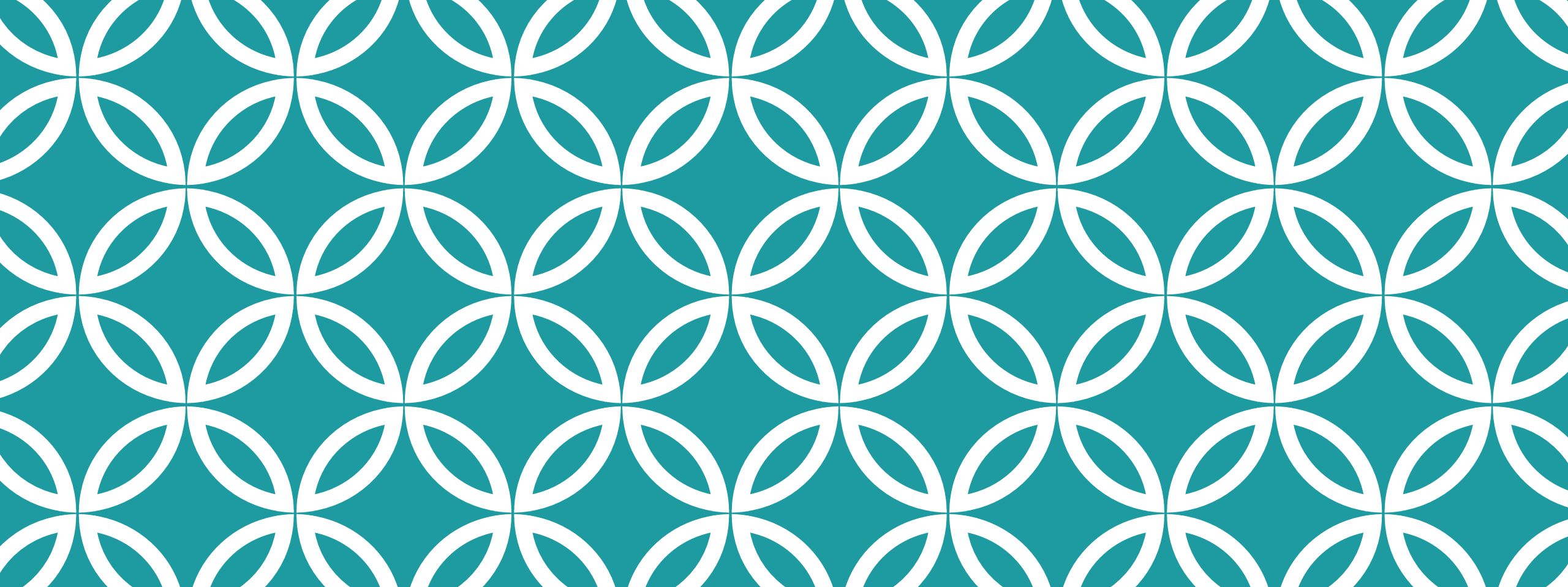

THANK YOU FOR WATCHING!

Iva, Nevna, Anja <3