



BENCHES

for different regions
of Slovenia



Co-funded by the
Erasmus+ Programme
of the European Union



SECONDARY SCHOOL
FOR DESIGN AND
PHOTOGRAPHY
LJUBLJANA



Networking for Entrepreneurship

Project Reference: 2017-1-SI01-KA202-035580

Start: 01-09-2017 - End: 31-08-2019



Co-funded by the
Erasmus+ Programme
of the European Union

Programme: Erasmus+

Key Action: Cooperation for innovation and the exchange of good practices

Action Type: Strategic Partnerships for vocational education and training



Rising unemployment, particularly among young people is a pressing problem faced by all European governments. Increasing employment among young people is an important priority. Due to this fact, as well as because of recent serious economic crisis in Europe, entrepreneurial spirit and business awareness have become even more important among students. We have found that students in secondary vocational education (and others as well) need to increase their entrepreneurial skills to be able to think about working in their own businesses.

The reality in partners' school systems shows students educated in different programs have with no or very random contacts with each other and lack of global knowledge of how to start their own business. In this project we combined three different fields of school education - production, marketing and design to achieve the common goal of potential commercial success.

Of great importance is also that students need some practical knowledge from external experts working in companies. That's why we provided new/upgraded curriculum named NET-ENT (Networking for Entrepreneurship).

By Networking we mean:

- interaction between the different schools, school programs
- linking education with the labor market
- networking and exchange of experiences from different EU countries
- establishing networks between students of different programs

In order to do this innovative methods in education are needed - new approaches to teaching and learning. Teachers were trained to change their teaching methods and meet with different challenges. They should establish supportive relationship, be professional, inspiring and support students throughout the project from the early steps (identifying problems or customers' needs - idea - problem solving) through progress monitoring until the goal is reached.

Students will benefit from entrepreneurial learning by developing collaborative planning, by understanding essential integration between different areas/programs to create commercially interesting products and start successful business, as well as essential skills and attitudes such as creativity, initiative, tenacity, teamwork, resilience, understanding of risk and a sense of responsibility. The entrepreneurial mindset will help students to put ideas into action and become self-confident in order to meet needs of the real market. It will help them to be more enterprising, competitive and innovative, thus becoming more employable .

1st Bench / "Šjorca" / Team 2.b

region: Primorska / landscape / moodboard



1st Bench / "Šjorca" / Team 2.b

region: Primorska / characteristics of the region / moodboard





1st Bench / "Šjorca" / Team 2.b

region: Primorska / salt pans of Piran / moodboard



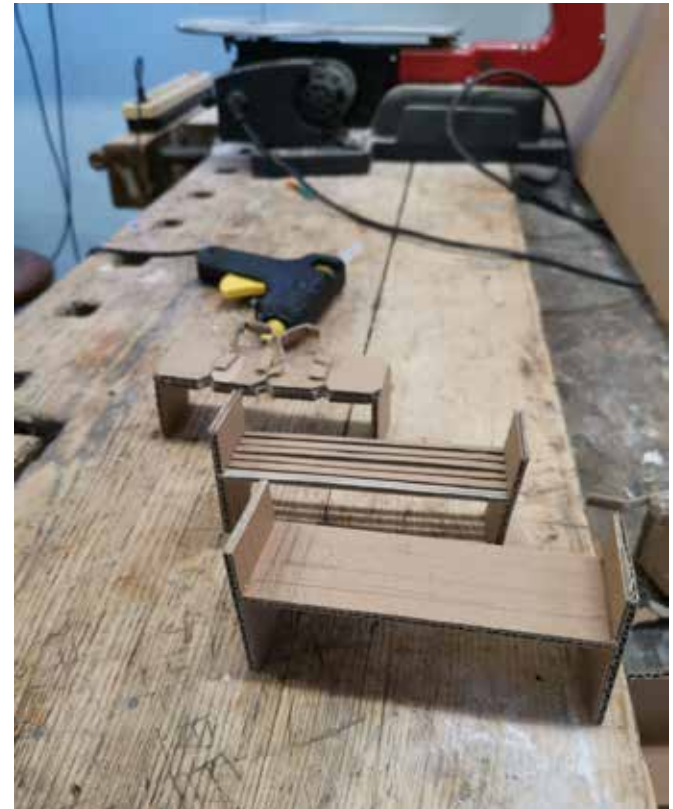
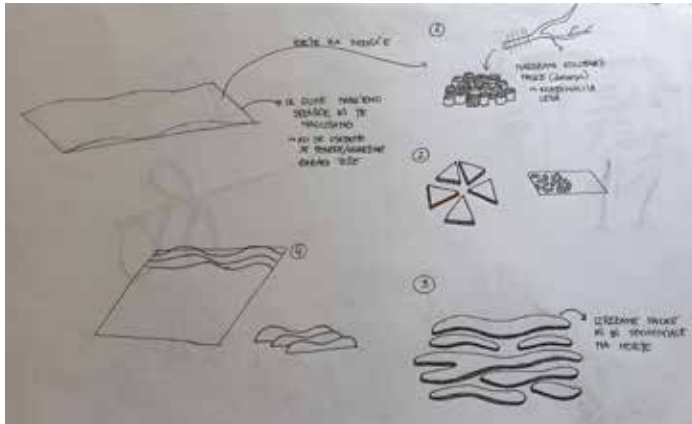

1st Bench / "Šjorca" / Team 2.b

working process / Maja Brus, Val Mohorčič Krapež, Nika Oblak, Hana Polak



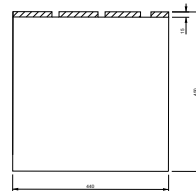
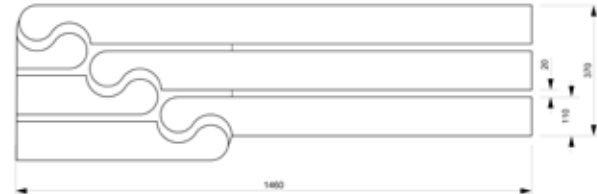
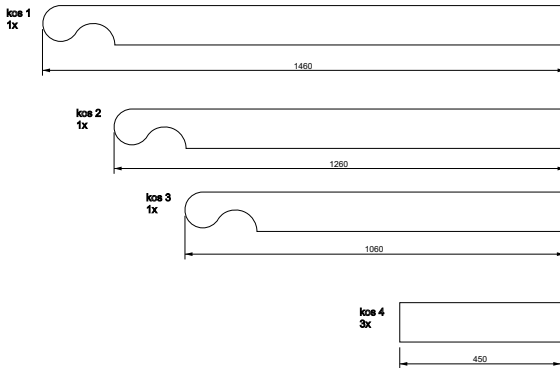

1st Bench / "Šjorca" / Team 2.b

working process / prototype





1st Bench / “Šjorca” / Team 2.b

3D Render

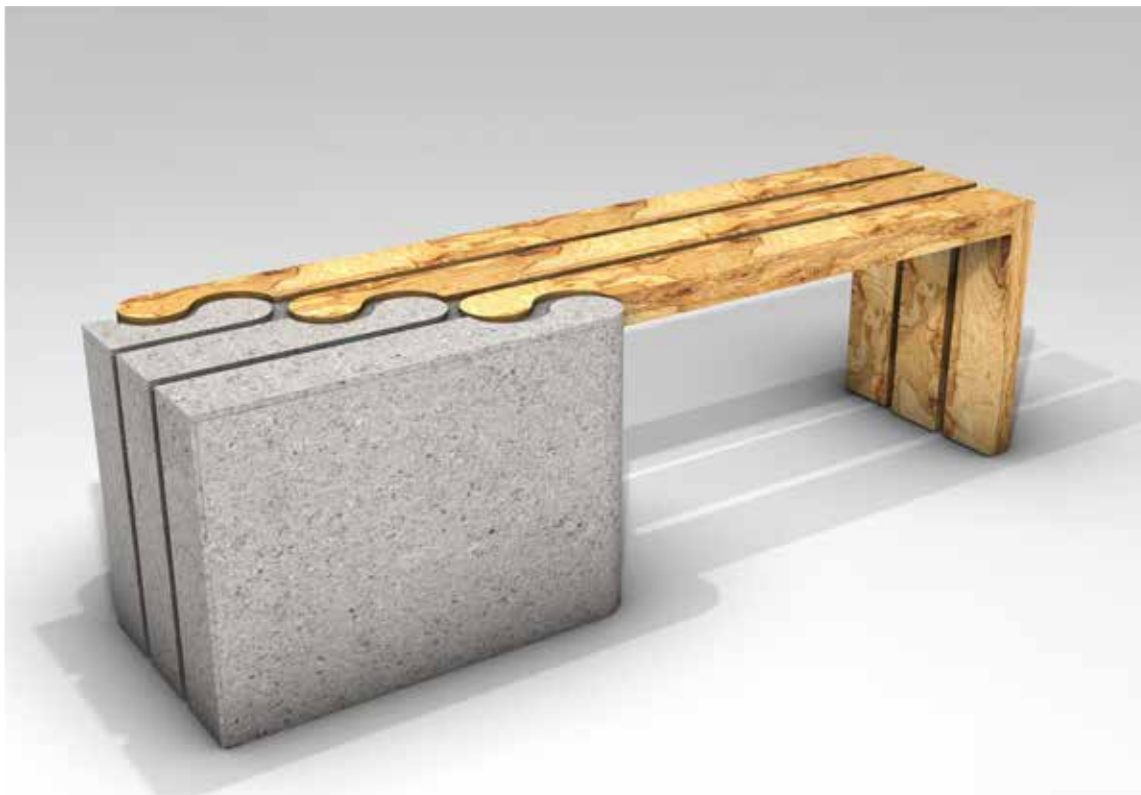

2nd Bench / “Zemljanka” / Ana Topole

region: Prekmurje / landscape / moodboard



Mura



Negovsko jezero



2nd Bench / “Zemljanka” / Ana Topole

region: Prekmurje / characteristics of the region / moodboard



remenke



ZNAČILNOSTI



pozvačín



Babičev mlin

2nd Bench / Bench "Zemljanka" / Ana Topole

technical plan

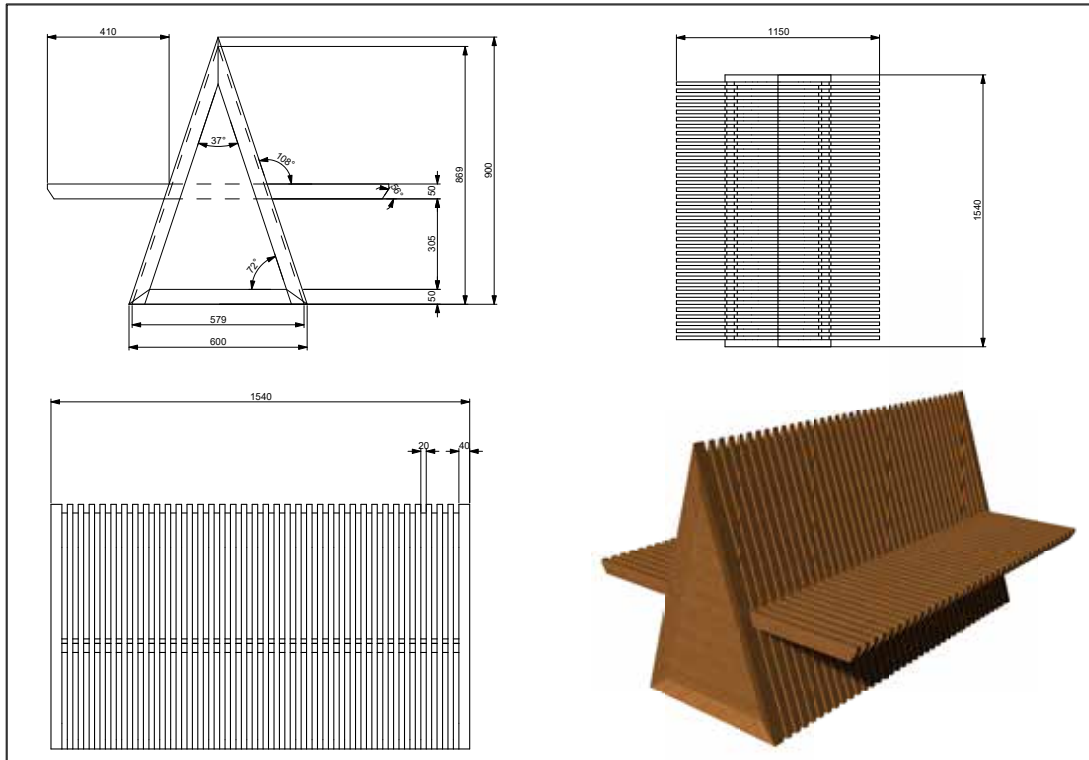

2nd Bench / Bench "Zemljanka" / Ana Topole

3D render

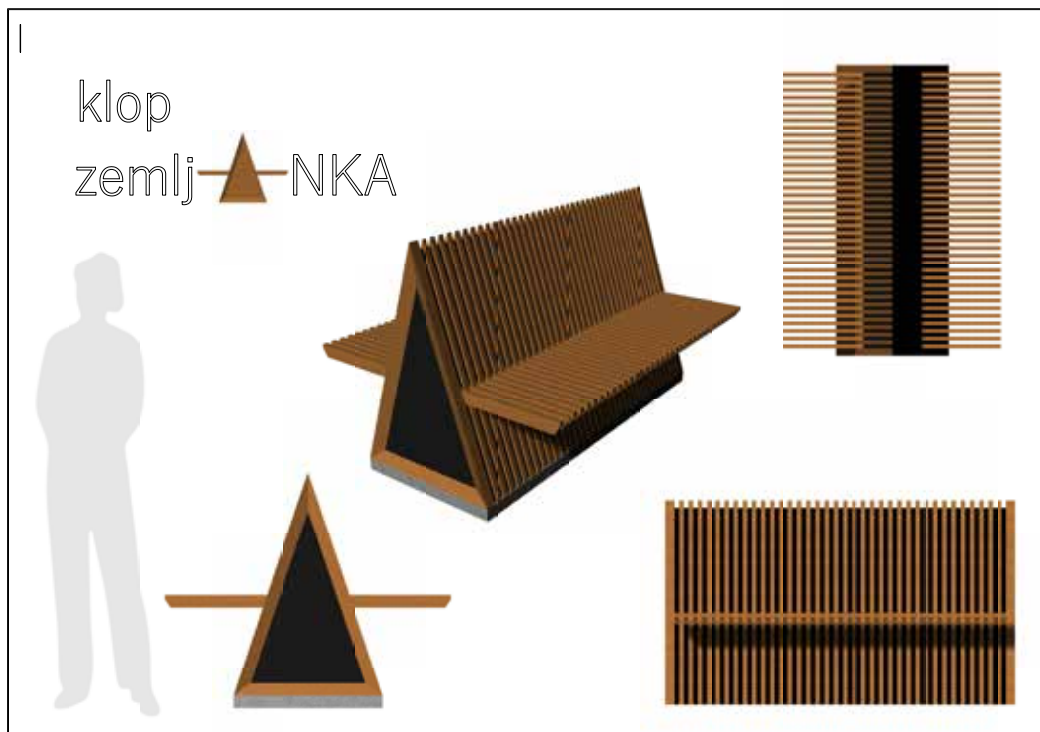

2nd Bench / Bench “Zemljanka” / Ana Topole

sketches / model / corrugated cardboard

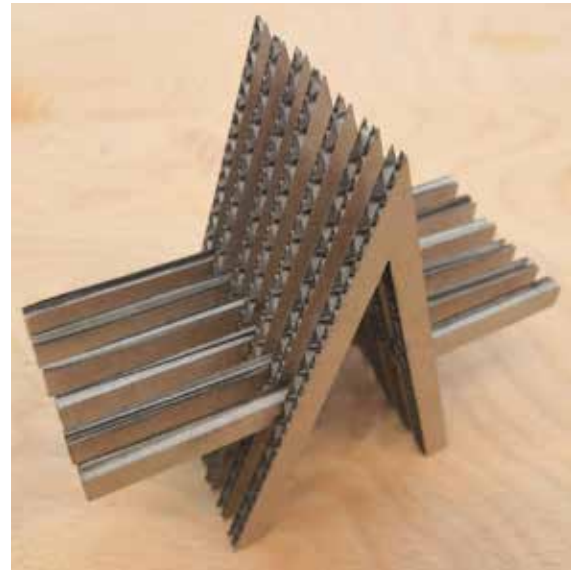
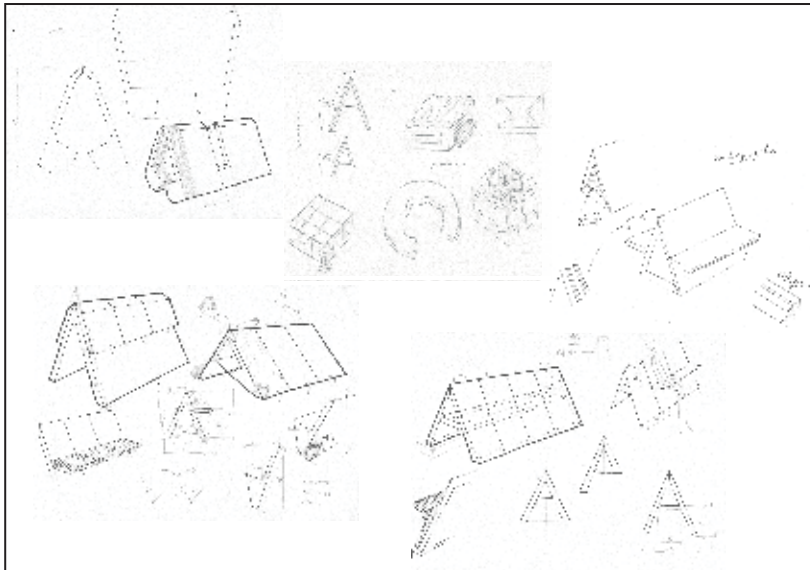

2nd Bench / Bench “Zemljanka” / Ana Topole

3D render

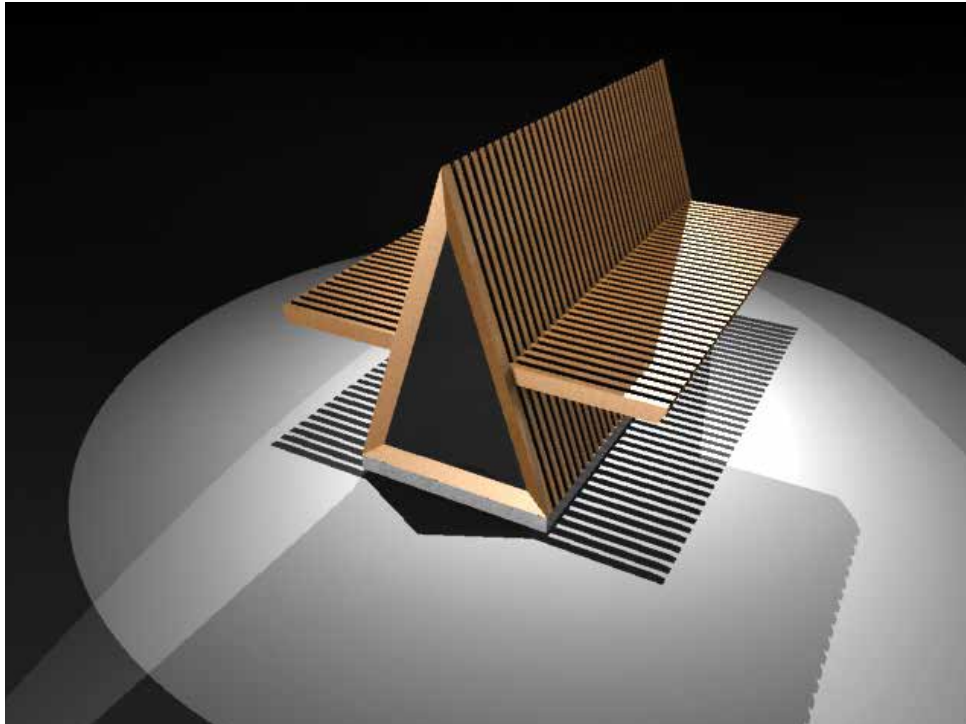

3rd Bench / "Family Bench" / Žiga Dolinar

region: Gorenjska / architecture / moodboard

PLANICA



ALJAŽEV STOLP



BRDO PRI KRANJU



PLANŠARSKKE KOČE



VODOVODNI STOLP



RASTLINE



3rd Bench / “Family Bench” / Žiga Dolinar

region: Gorenjska / fauna / moodboard

MUFLON



KOZOROG

GAMS



3rd Bench / "Family Bench" / Žiga Dolinar

sketches

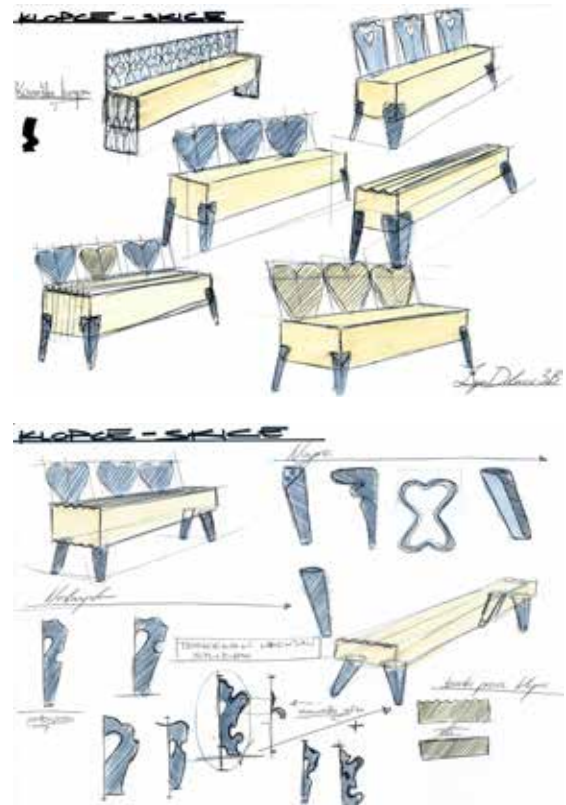

3rd Bench / "Family Bench" / Žiga Dolinar

sketches

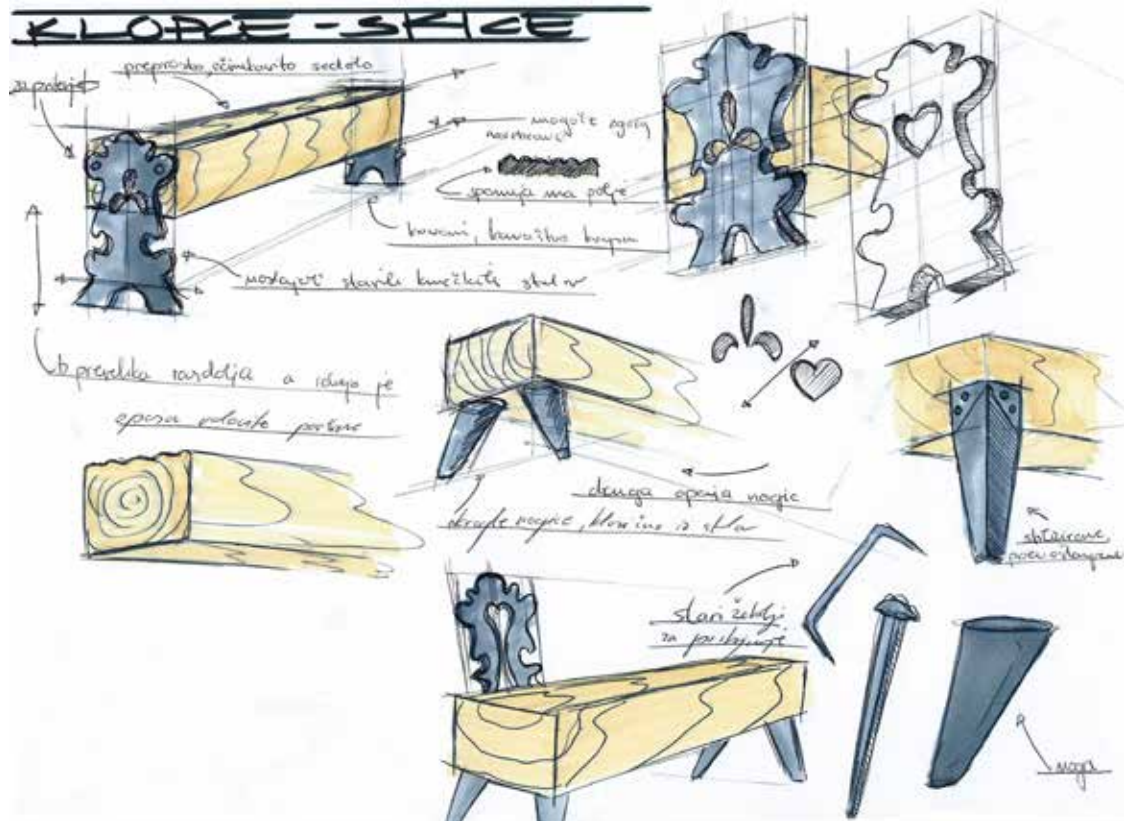

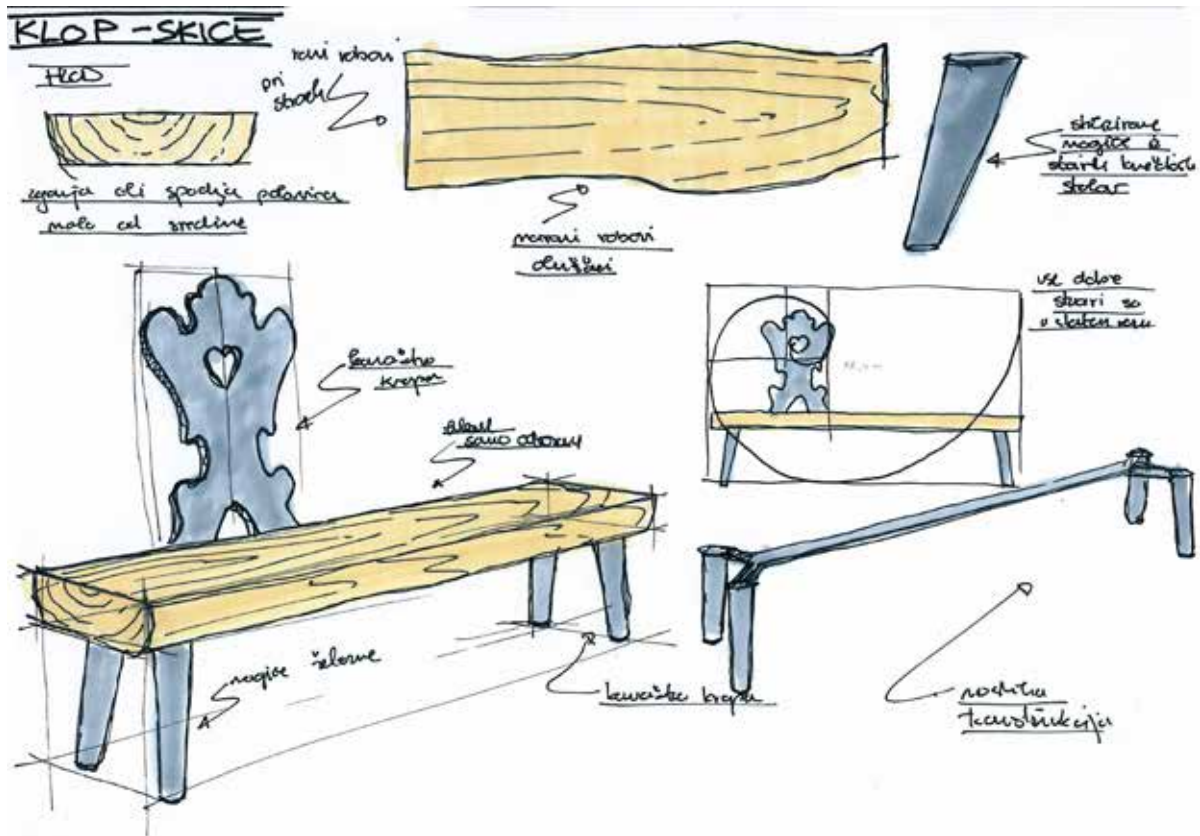

3rd Bench / “Family Bench” / Žiga Dolinar

choosing the wood



3rd Bench / “Family Bench” / Žiga Dolinar

making a model

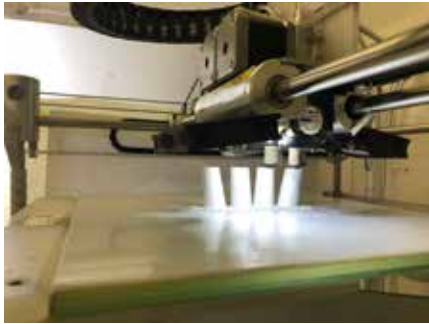

3rd Bench / “Family Bench” / Žiga Dolinar

3D render



4th Bench / “VinoGrad” / Ana Turičnik

region: Štajerska / landscape / moodboard



4th Bench / "VinoGrad" / Ana Turičnik

region: Štajerska / sketches / moodboard



4th Bench / “VinoGrad” / Ana Turičnik

technical plan

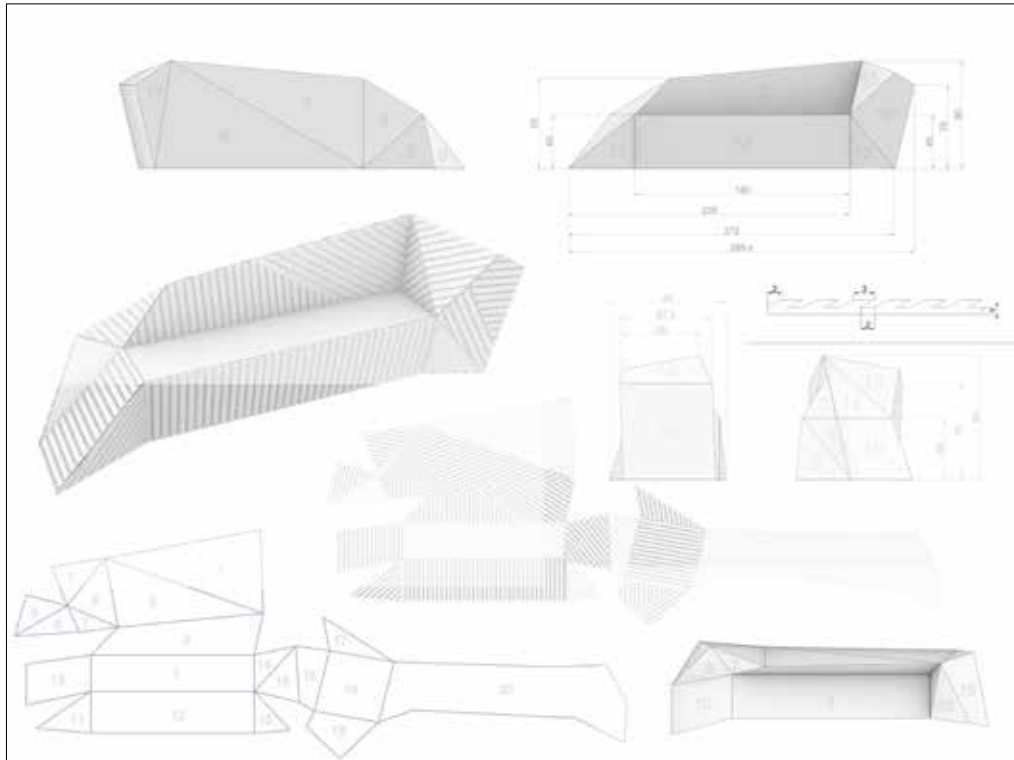

4th Bench / “VinoGrad” / Ana Turičnik

3D render

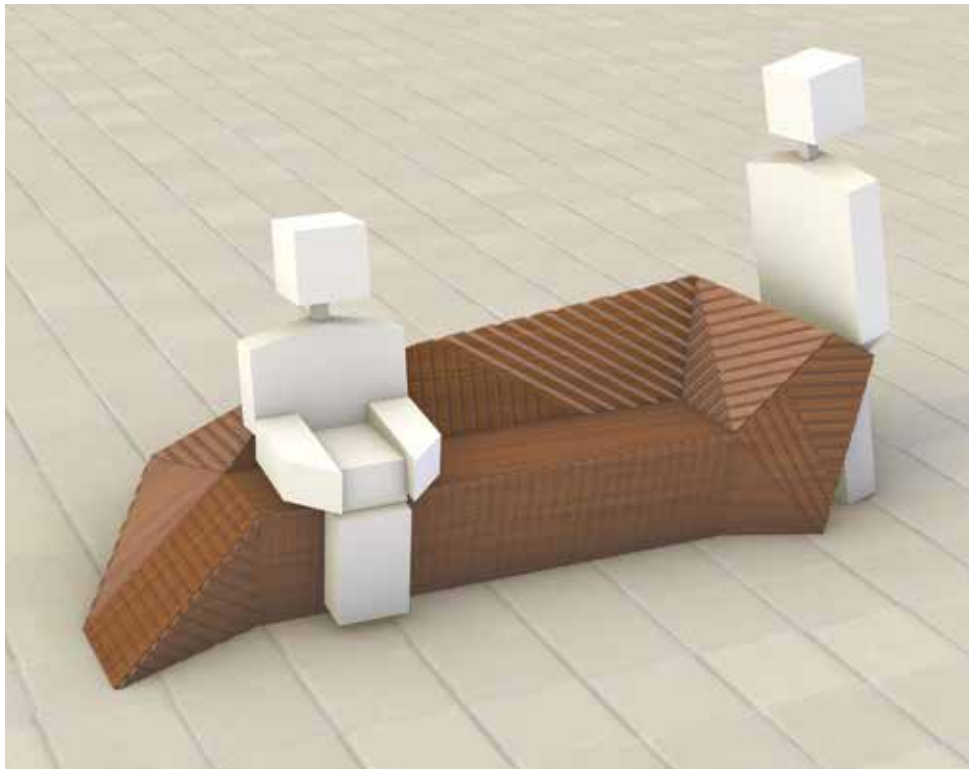

5th Bench / “Cerknica Island” / Mark Majcen

region: Notranska / towns / moodboard



NASELJA NA NOTRANJSKEM



5th Bench / “Cerknica Island” / Mark Majcen

region: Notranska / tourist attractions / moodboard



PREDJANSKI GRAD



TURISTIČNE
ZANIMIVOSTI
NOTRANJSKE



POSTOJNSKA JAMA



CERKNIŠKO JEZERO



5th Bench / "Cerknica Island" / Mark Majcen

sketches

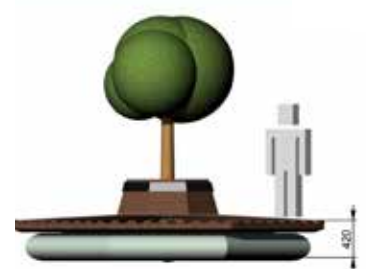
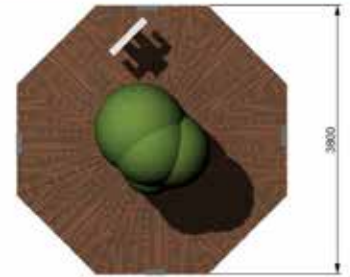
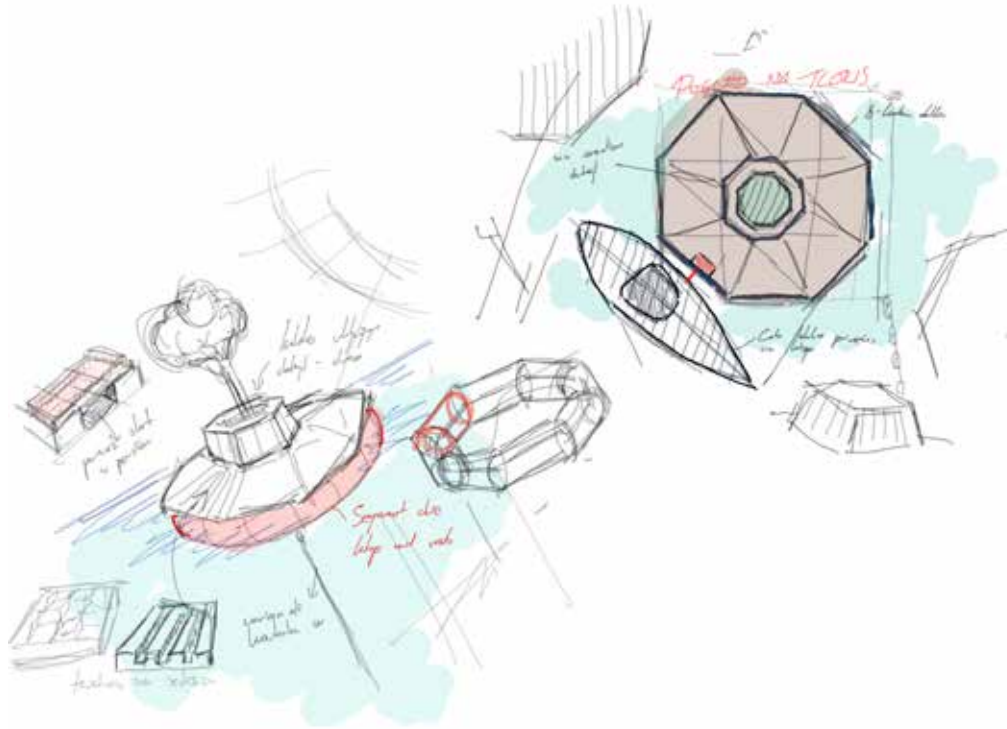

5th Bench / “Cerknica Island” / Mark Majcen

3D render

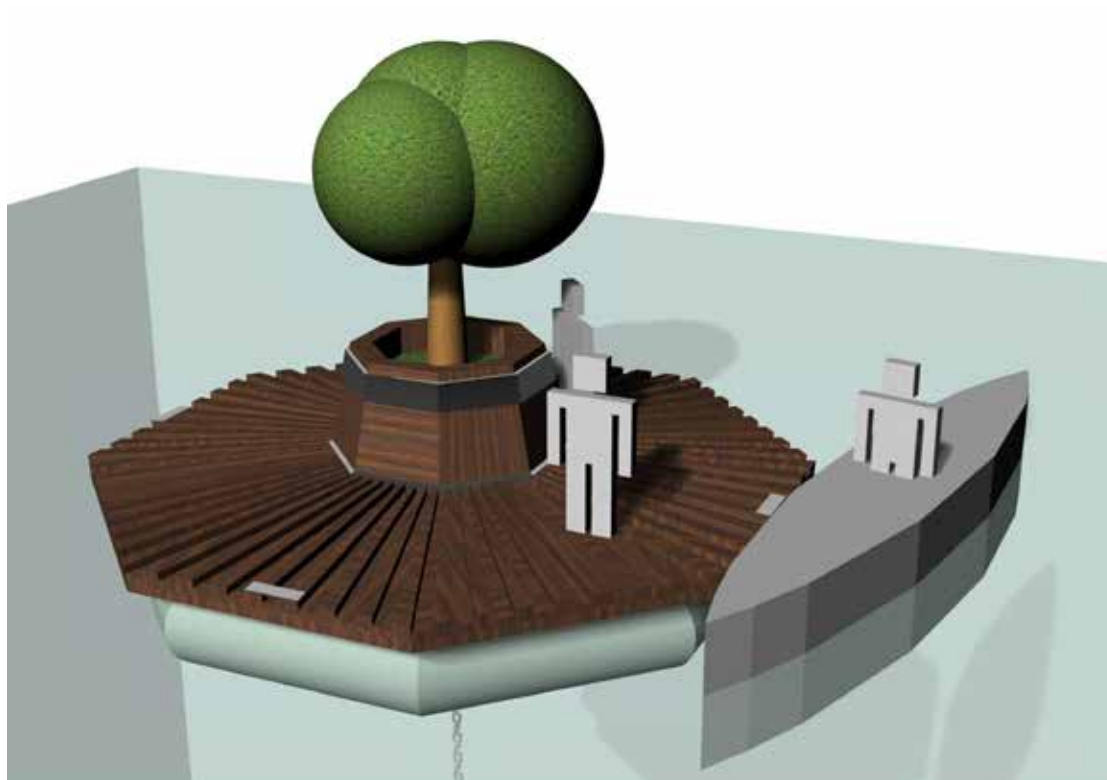

6th Bench / "Pručka" / Katja Brišar region Goriška / moodboard / culture & history



6th Bench / “Pručka” / Katja Brišar

region Goriška / moodboard / culture & history

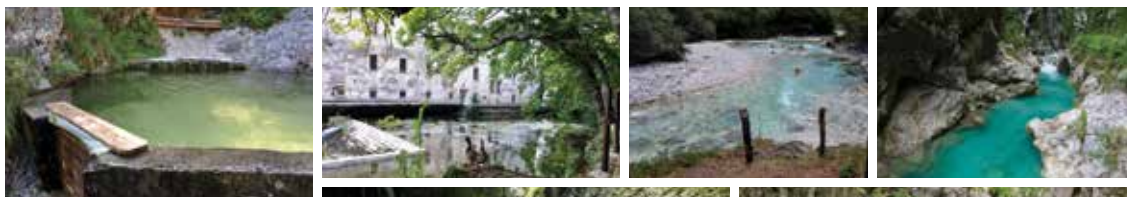
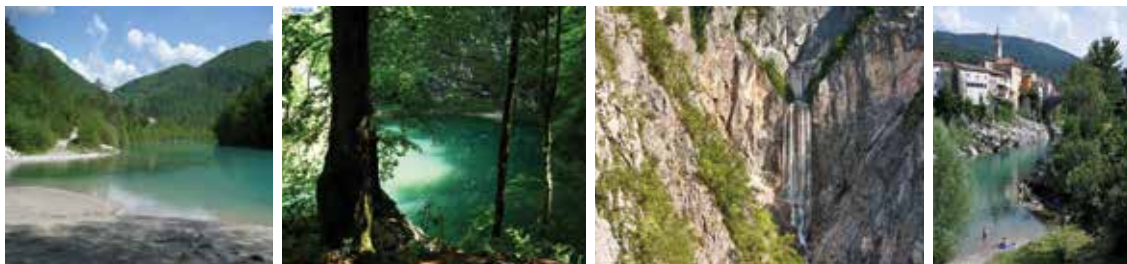

GORIŠKE
NARAVNE ZNAMENITOSTI



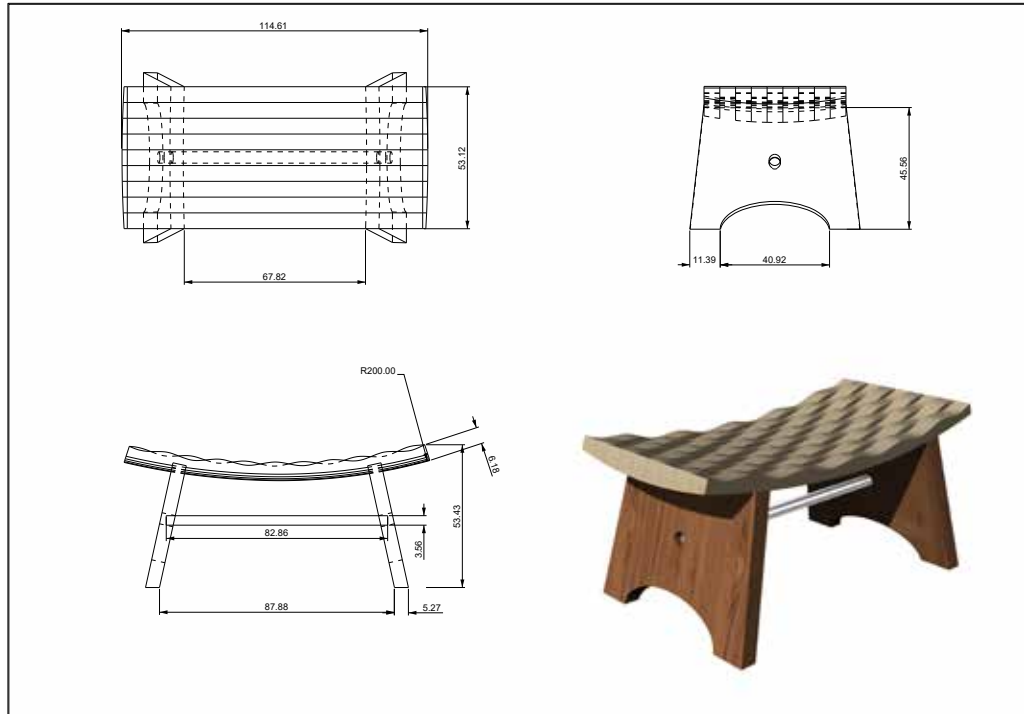

6th Bench / “Pručka” / Katja Brišar

3D render



7th Bench / "BearBench" / Ana Tudjan

region Dolenjska / sketches

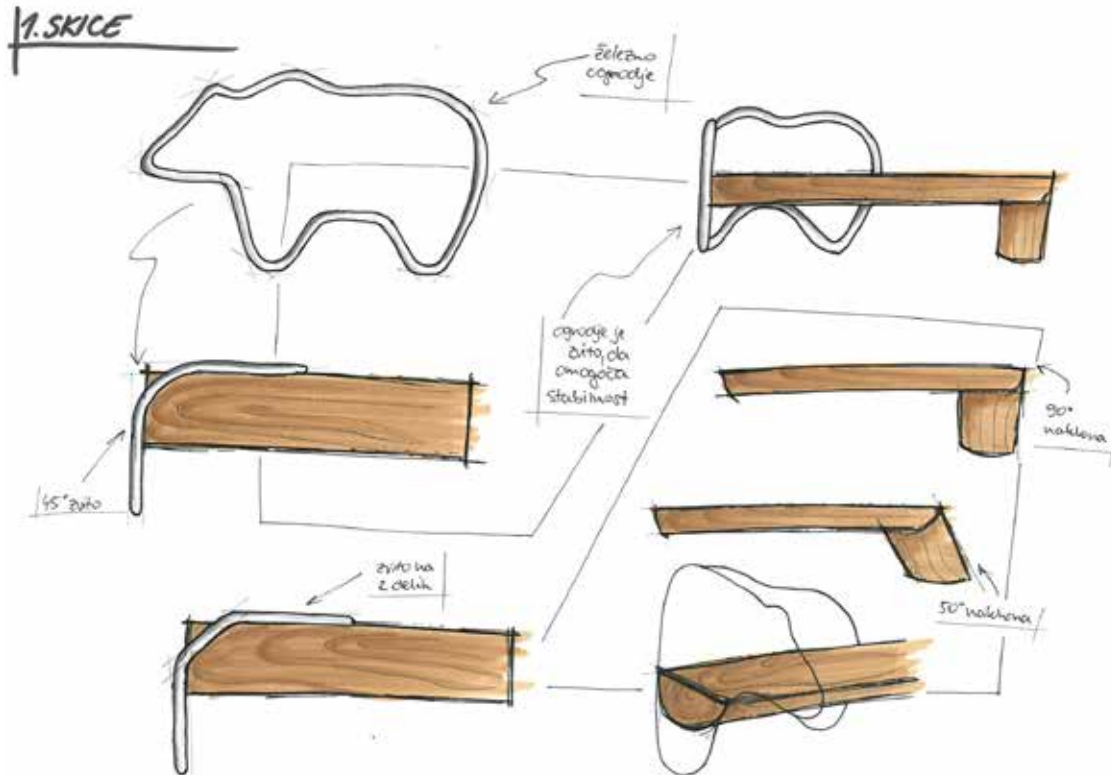

7th Bench / "BearBench" / Ana Tudjan

sketches

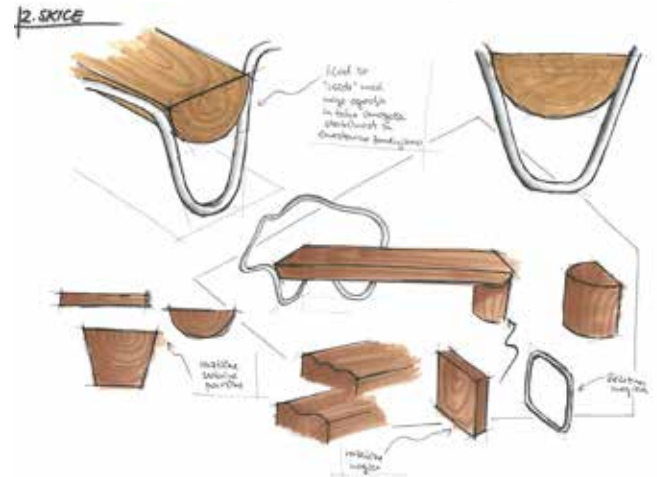
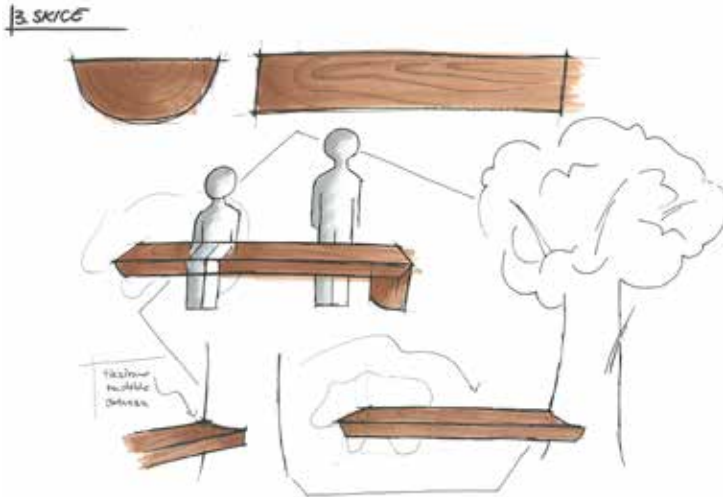

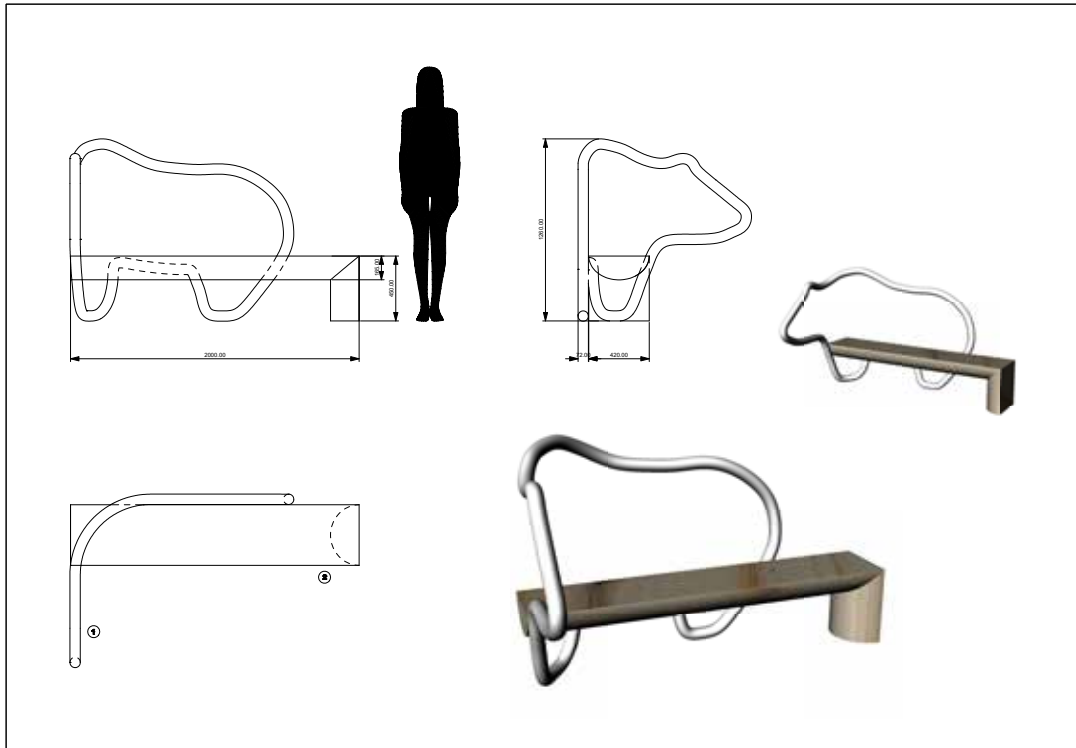

second technical plan

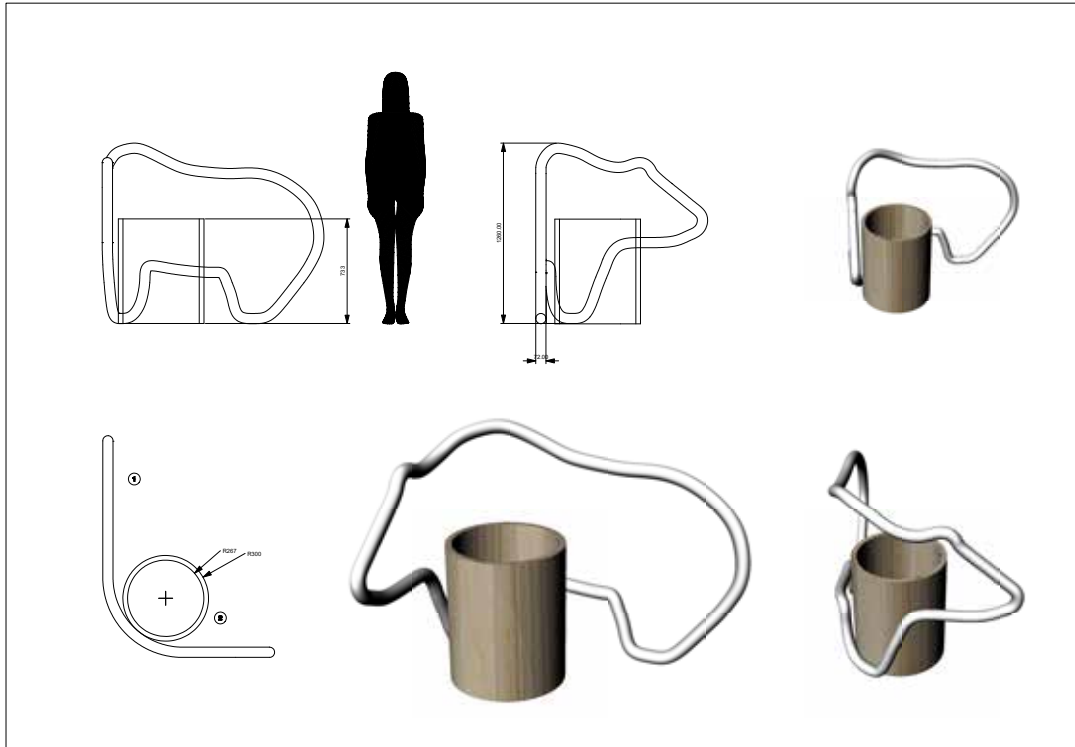

7th Bench / “BearBench” / Ana Tudjan

3D render





Co-funded by the
Erasmus+ Programme
of the European Union



SECONDARY SCHOOL
FOR DESIGN AND
PHOTOGRAPHY
LJUBLJANA

Coordinators & Mentors

Saša Vitežnik Jelen
Aleksandra Ardalič
Damijan Kracina

Product Design

Uroš Hohkravt
Luka Jančič
Aljaž Mrak
Igor Stanko

Graphic Design

Saša Vitežnik Jelen

Students

Product Design

3rd year:

Katja Brišar
Žiga Dolinar
Mark Majcen
Ana Topole
Ana Turičnik
Ana Tudjan

2nd year:

Maja Brus
Val Mohorčič Krapež
Nika Oblak
Hana Polak

Graphic Design

3rd year:

Jurij Hartman
Vid Skumavec

