

PROCES IZRADE KAMIŠIBAJ KAZALIŠTA

UZ "To je to!"

OŠ Matije Gupca, Zagreb

2020./2021.



Demonstracija izrade bautaja
- okvira za pripovijedanje
kamišibaj priča

BUTA 1:1

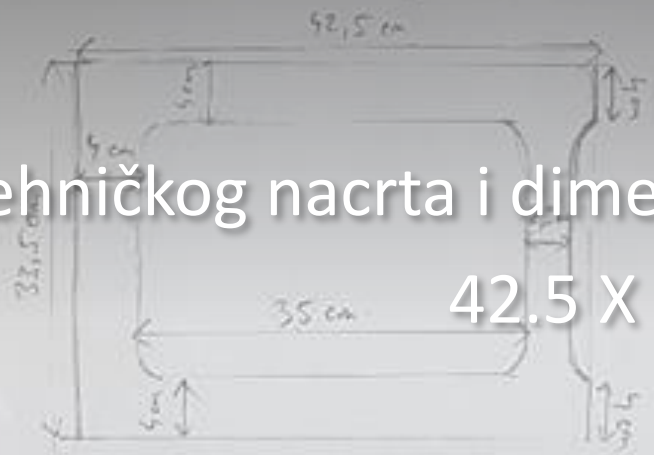
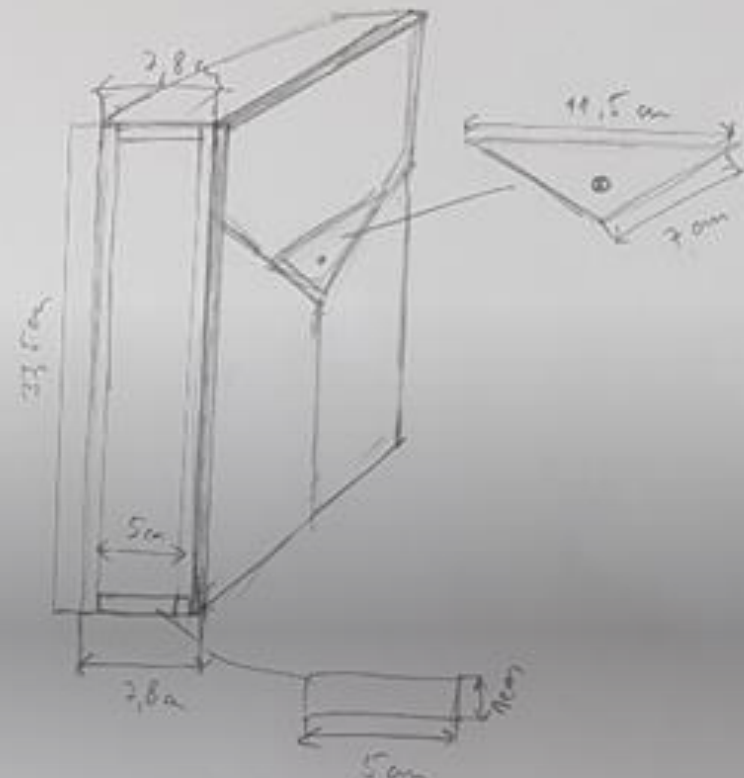
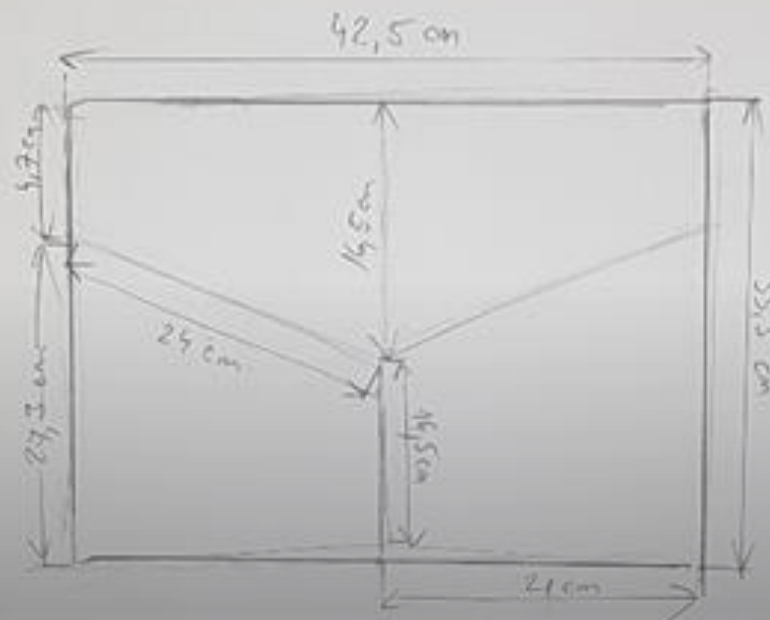



1. Crtanje tehničkog nacrtu i dimenzije sastavnih dijelova butaja na papiru

42.5 X 33.5 X 7.8 cm

A photograph showing two women in a workshop setting. They are both wearing face masks and dark clothing. They are leaning over a large, light-colored wooden board placed on a table. One woman is using a pencil to mark the board, while the other holds a long metal ruler against it. The background includes a wooden cabinet, a radiator, and a window with blinds. The text is overlaid in the center of the image.

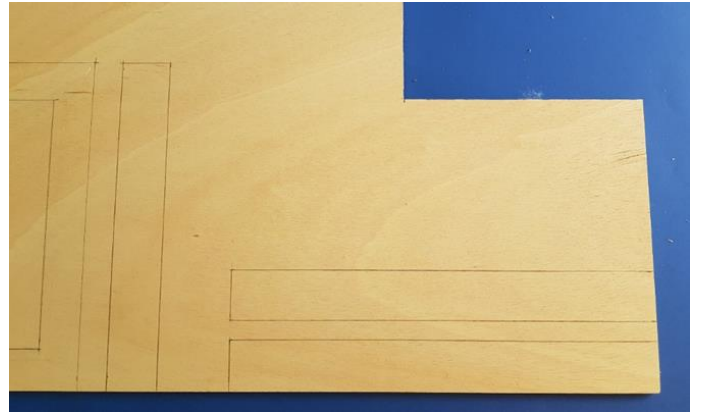
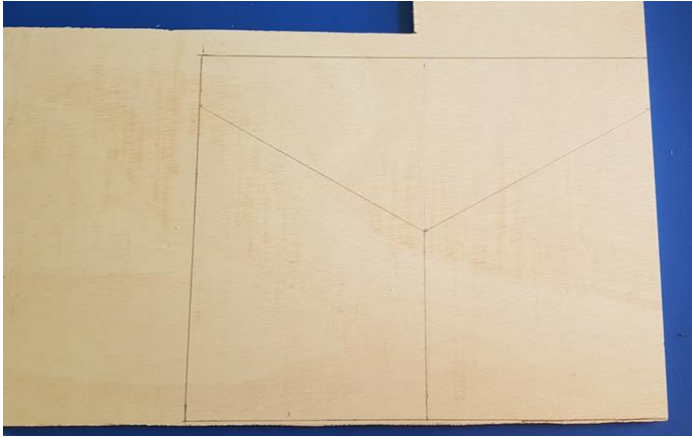
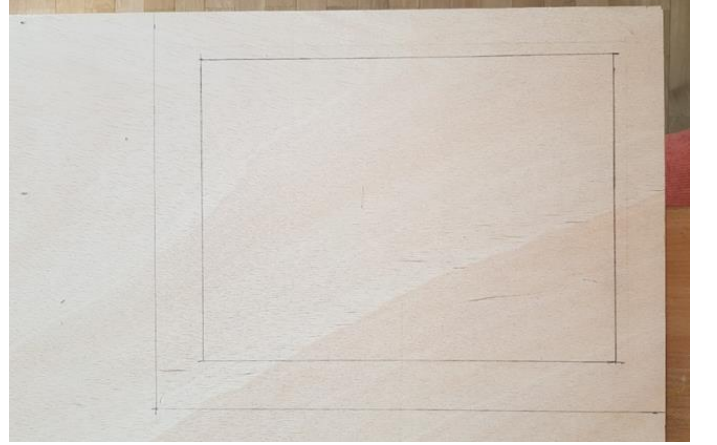
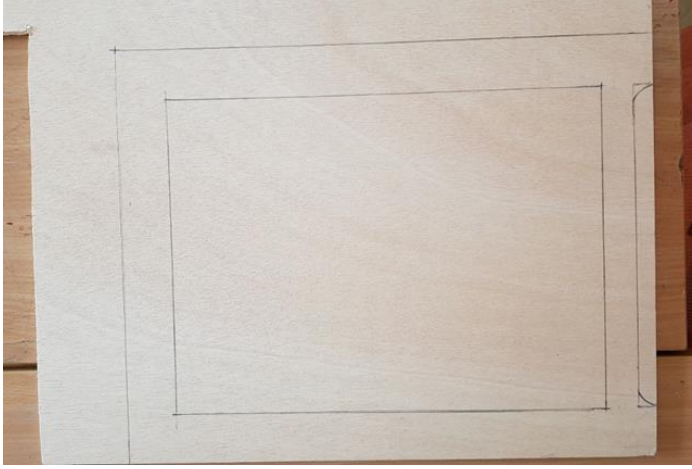
2. Prenošenje dimenzija sastavnih dijelova butaja na šperploču debljine 1 cm



A photograph showing two women in a workshop setting. The woman on the left, wearing a dark jacket and a light blue surgical mask, is operating a blue hand router on a large, light-colored wooden board. The woman on the right, wearing a black jacket and a black face mask, is holding the board steady with her hands. The workbench is cluttered with various tools, including a long metal ruler and a blue marker. The background features a slanted ceiling with a green structural beam and a window with a radiator below it. The floor is made of light-colored wood.

3. Izrezivanje dijelova butaja ubodnom pilom

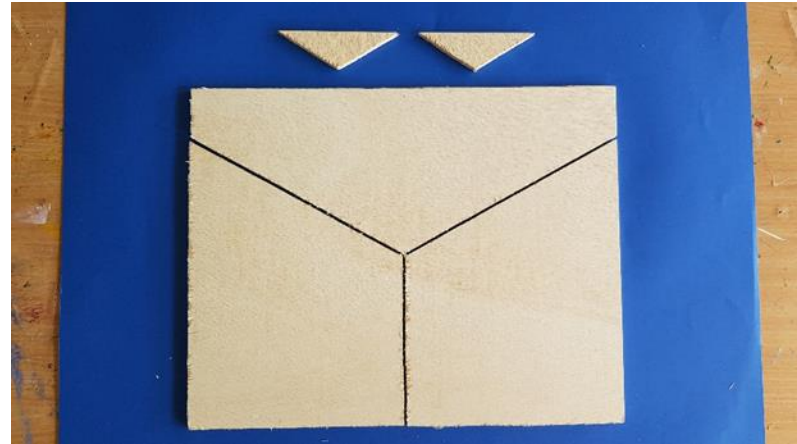

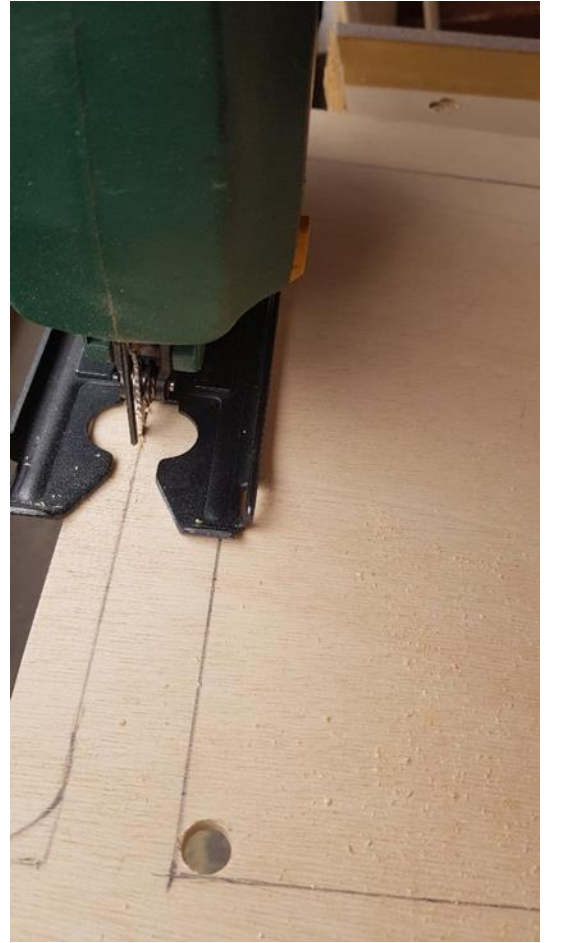

Sastavni dijelovi butaja



4. Brušenje rubnih dijelova butaja da budu glatki





A photograph showing two women in a workshop setting. The woman on the left is wearing a white long-sleeved shirt and a light blue surgical mask. She is holding a piece of wood. The woman on the right is wearing a black turtleneck sweater and has her hair in a ponytail. She is holding a small tool and a piece of wood. They are working at a large wooden table. On the table, there is a partially assembled wooden frame, a pink plastic cup, some papers, and other materials. The background shows a wooden cabinet and a green beam.

5. Nanošenje ljepila za drvo na rubove središnjeg dijela butaja
i spajanje u cjelinu





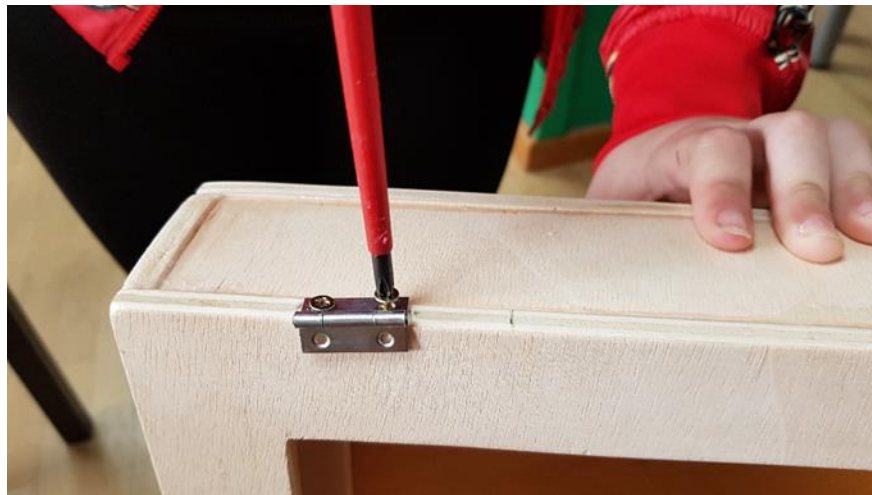

6. Bušenje rupa na središnjem dijelu butaja i na vratašcima
te spajanje tih dijelova pomoću šarki i vijaka za drvo

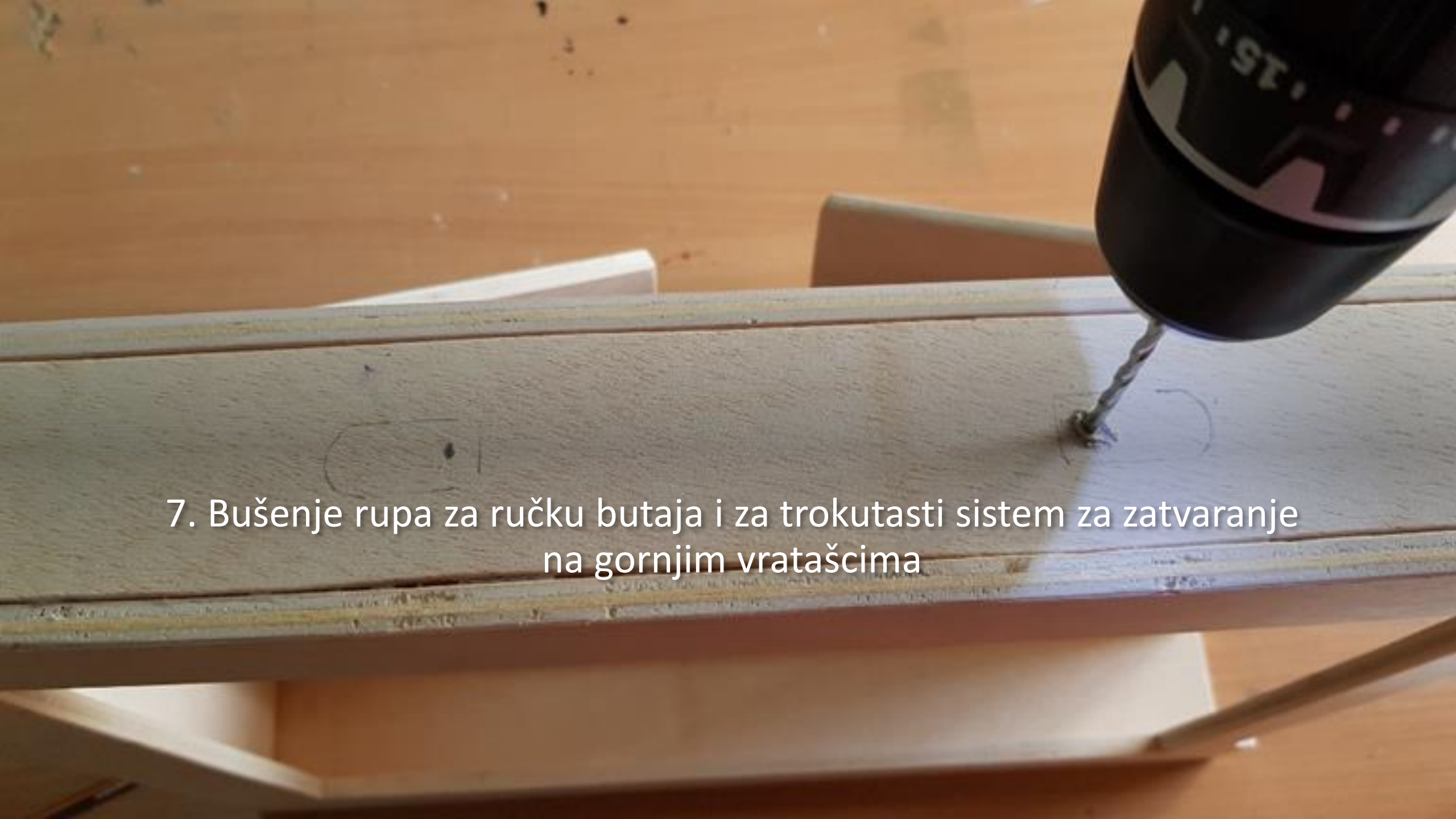

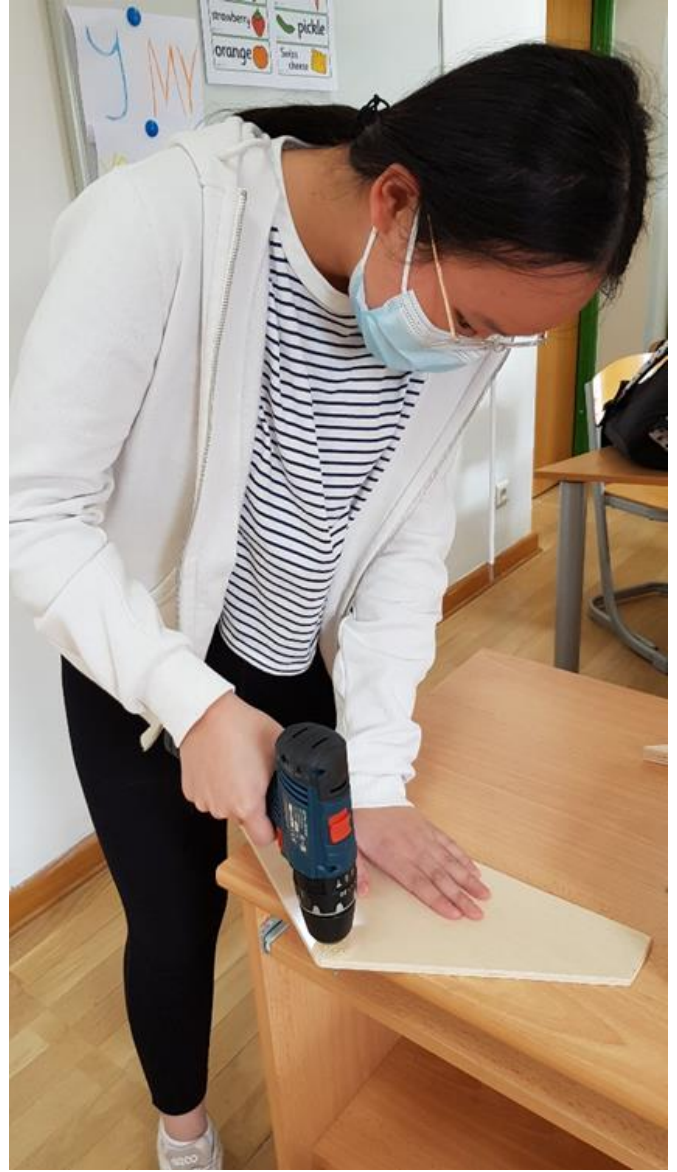

7. Bušenje rupa za ručku butaja i za trokutasti sistem za zatvaranje na gornjim vratašcima





8. Spajanje trokutastih dijelova sistema za zatvaranje na gornja vratašca

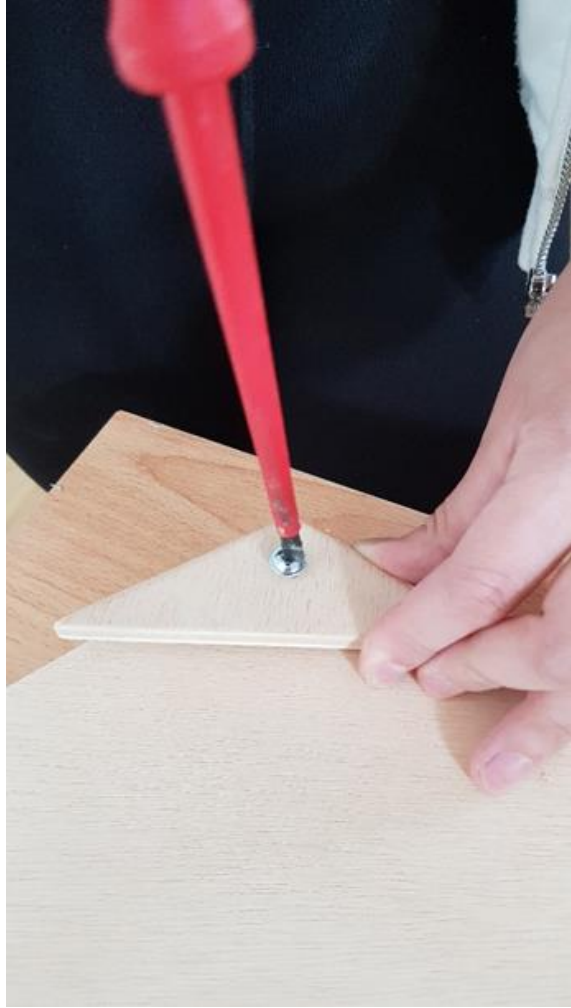



9. Spajanje gornjih vratašaca na središnji dio butaja pomoću šarki i vijaka za drvo



Sunday

Sunday

10. Konačno spojeni dijelovi u cjelinu butaja

we



11. Premazivanje butaja sa svih strana zaštitnim, tekućim pčelinjim voskom





Demonstracija izrade butaj kartica

1. Podjela legende *Ne tako strašni zmaj* na scene

1. Medvednica, u podnožju sela, bogata priroda, stoka
2. Ljudi u svađi, dolazak zmaja
3. Simpatični Zmajček u krupnom planu
4. Zmajček koji stuca i riga vatru
5. Ljeni Zmajček izvaljen na polju, gladni i mršavi seljani.
6. Špilja - ulaz
7. Špilja - pečeni fazan, srna, jelen
8. Zmajček u pećini, seljani mu donose hranu
9. Zmajček padne s kreveta
10. Scena potresa u visokoj zradi u Zagrebu
11. Tužan Zmajček
12. Zmajček koji vježba kako bi bio fit



2. Ilustriranje scena legende slikarskom tehnikom gvaša







3. Digitalno uređene kamišibaj kartice i ispridane na A3 format







4. Gotov proizvod - kamišibaj
kazalište
i legenda o *Ne tako strašnom zmaju*





Alphabet

Aa	Bb	Cc	Dd
Ee	Ff	Gg	Hh
Ii	Jj	Kk	Ll
Mm	Nn	Oo	Pp
Qq	Rr	Ss	Tt
Vv	Ww	Xx	Yy
Zz			

Monday
Tuesday
Wednesday
Thursday
Friday
Saturday
Sunday

GOOD JOB

THINK...TRY BETTER

STOP...COOL OFF

To je to!

